

design statement.

autonomous mood regulation dispenser



issue.

Our design proposes a possible world where automated processes present patients with a "quick fix" to their mental health issues in the form of medication. Patients are able to stay in the comfort of their own home to receive mood related medication. The pills patients receive are inscribed with succinct phrases of comfort such as "you'll be fine" and "don't be nervous". Empathy for one's own well being and self-awareness is lost in using this device as the pills they are given offers merely a surface level diagnosis dependent on idea that medicating equates to healing.

position.

The design is meant to explore our dependence on medication as a 'solution' for health related issues. The medication provided is based on a shallow assumption read by the device which lacks proper labelling. Proper labelling would explain the chemical makeup of the pills, when and how much the user should consume, and the side effects that come with using the pills. The only indication of "help" users receive from its false sense of positivity with a message enscripted onto the pill's surface. This device employs a critique on both over-reliance of medication as the sole means to get 'better', and a jab at stigma around mental health, especially for the phrase "take a chill pill". The team believes that this abuse of dependence on medication over holistic means of self-care can be damaging to oneself.

audience.

Automated targets impressionable patients that are treated for mood-regulated illnesses (depression, bipolar, anxiety), who are more comfortable receiving mental health solutions in their own home. These users willingly place their personal health in the hands of others, as often it can be cumbersome to help themselves. As well, without proper knowledge on mental health issues, this audience may be told to "just relax" or "get over things" by neurotypical / uninformed people.

context.

The device is situated at an affected patient's home who feel the need to regulate their mood with assistance. It may be present at their nightstand, kitchen, or bathroom, wherever one feels most comfortable consuming their medication.

automated.

the aid you seek is in your hands. 😊

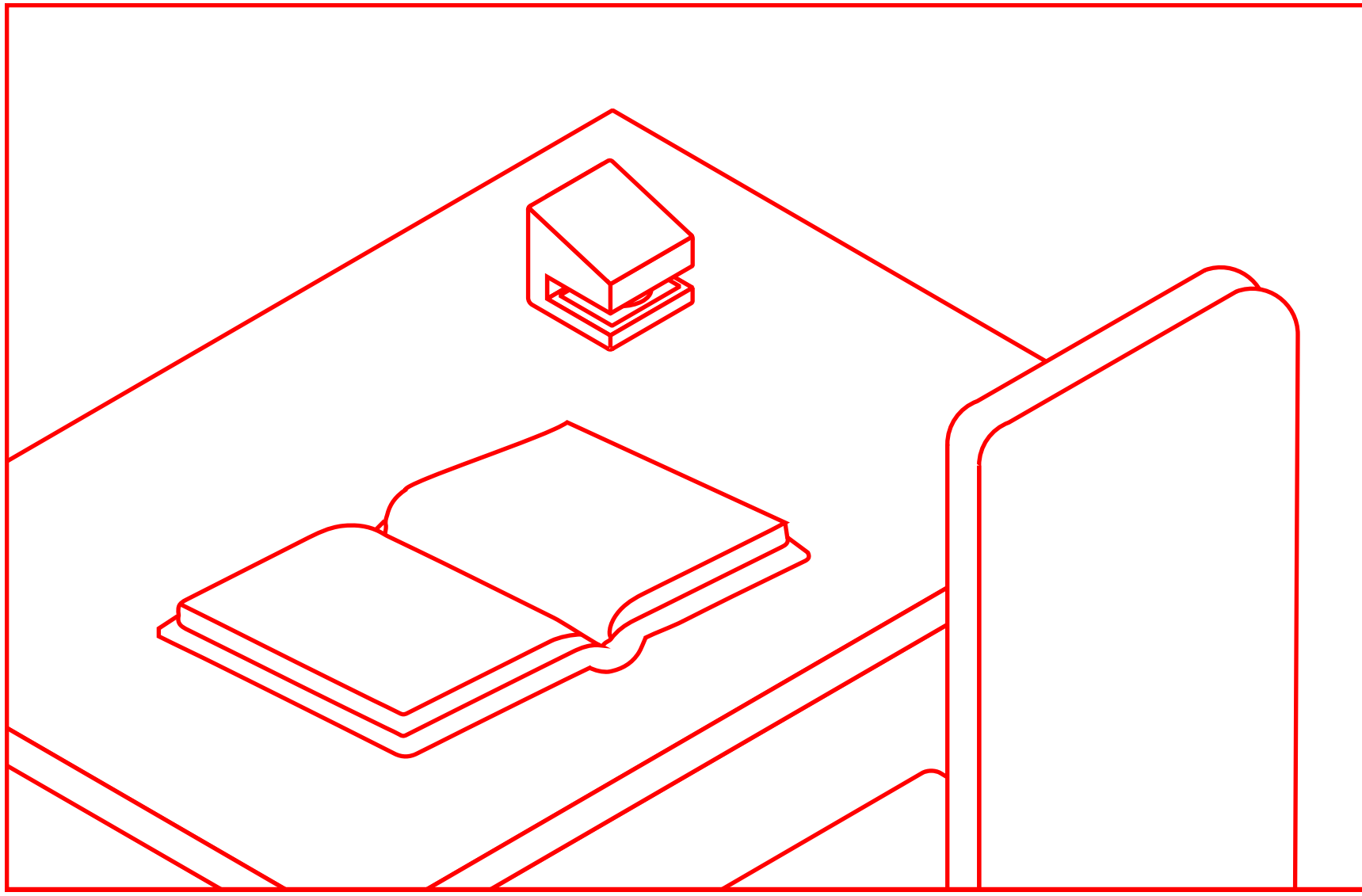

place automated on a flat surface.

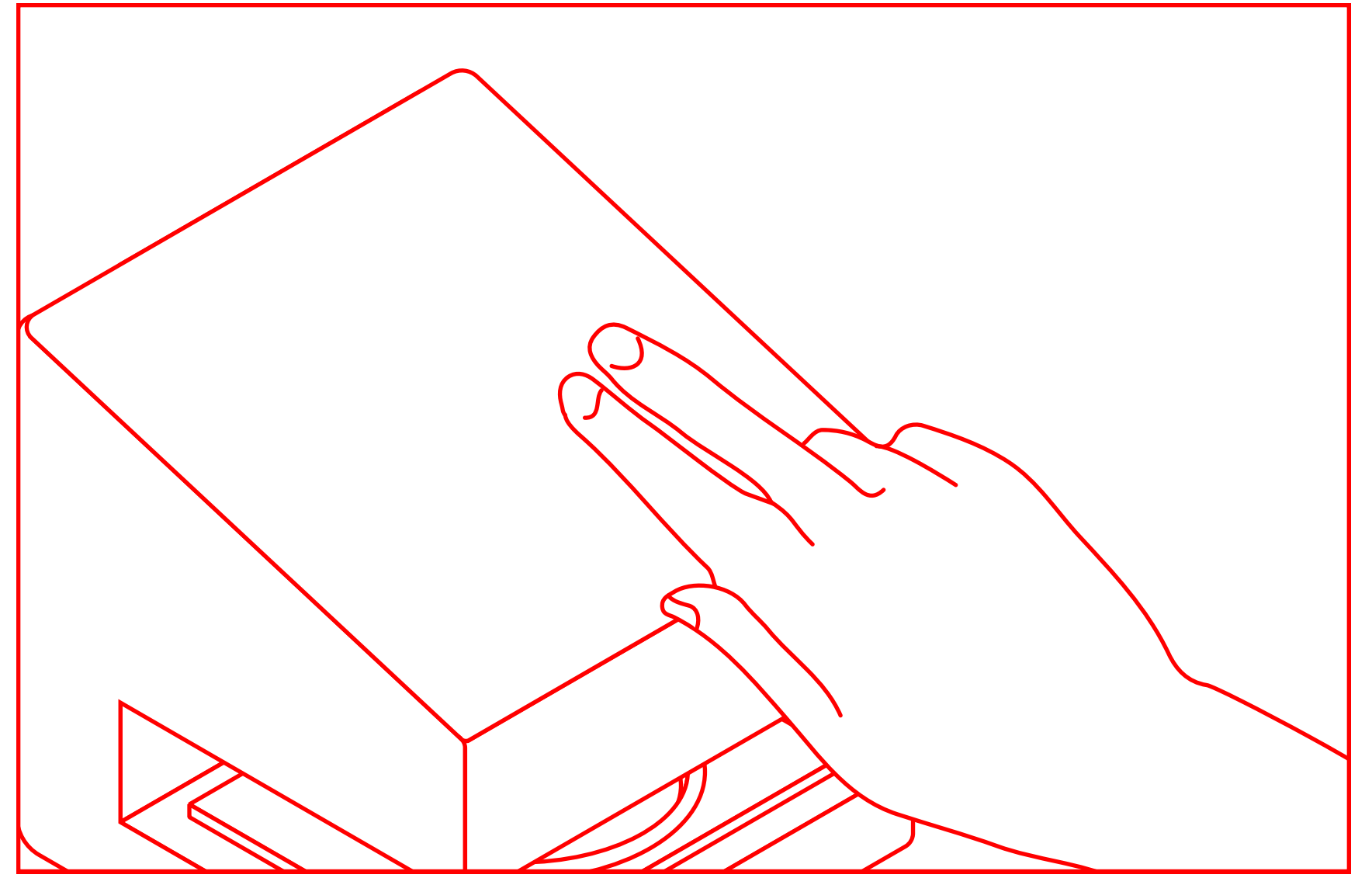

using two fingers, gently press the surface for approx. 2- 4s.

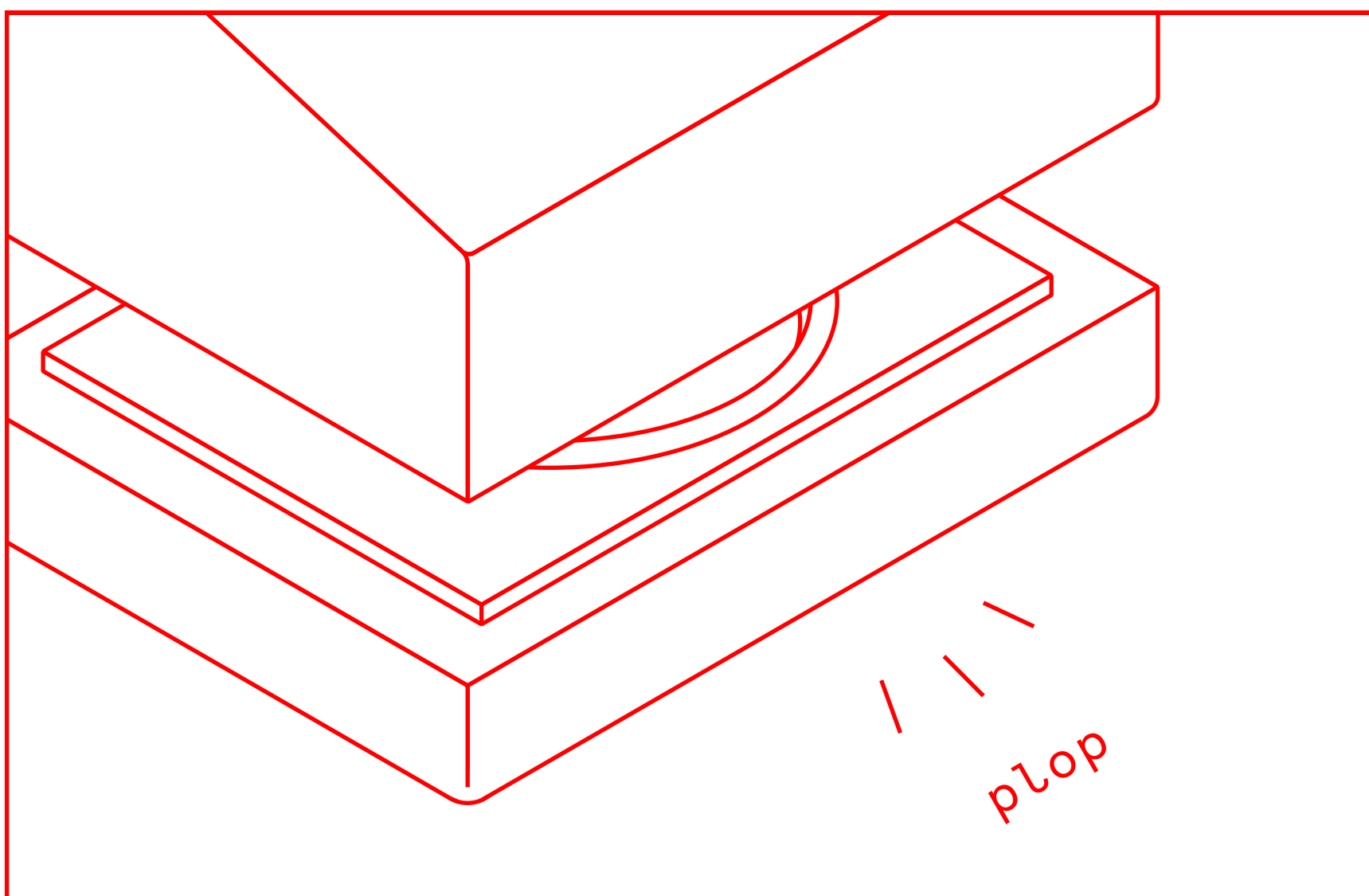

release fingers from automated once your specially formulated pill is deposited into the bottom tray.

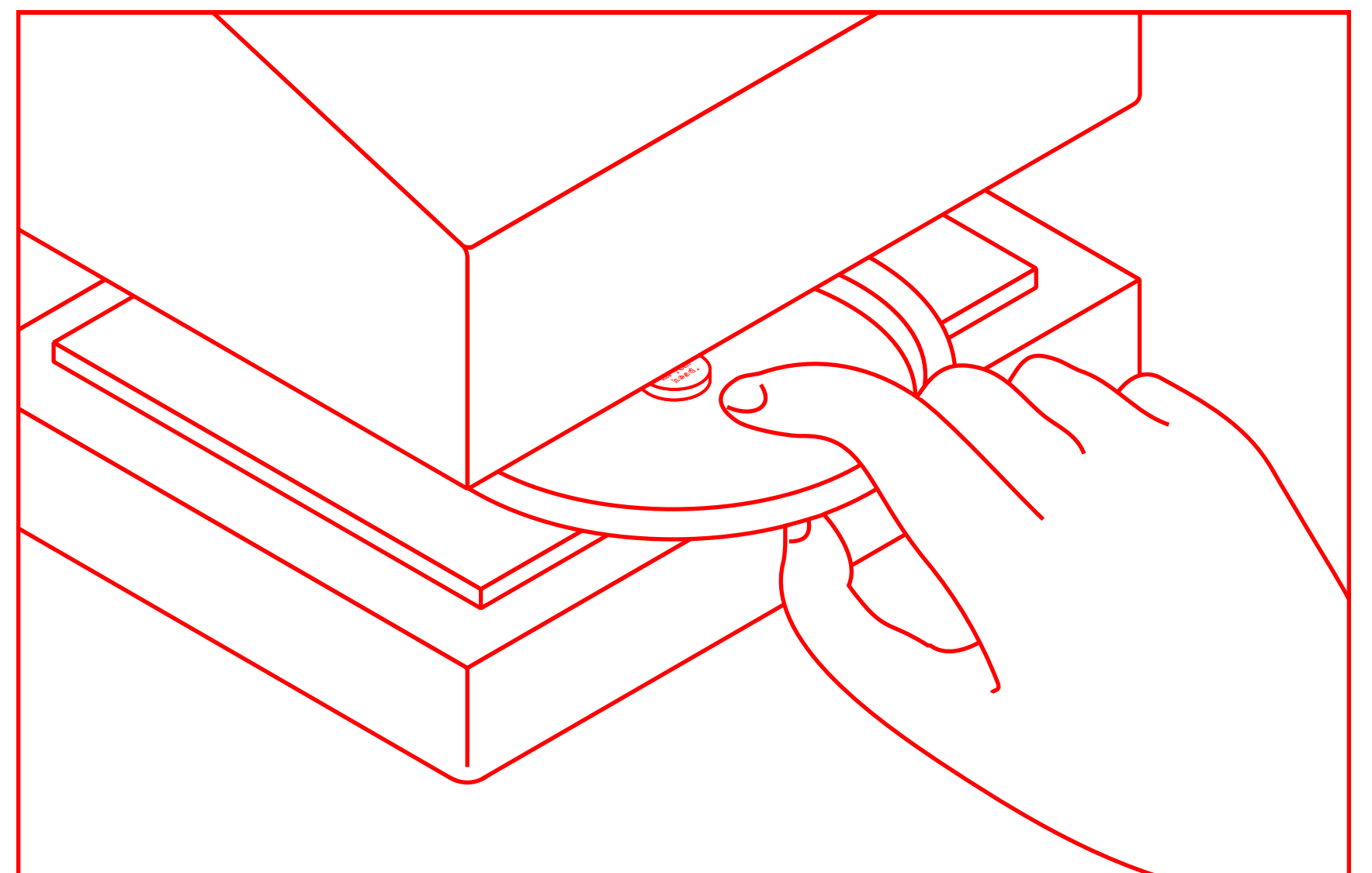

slide the tray outward to retrieve pill.



remove the pill.

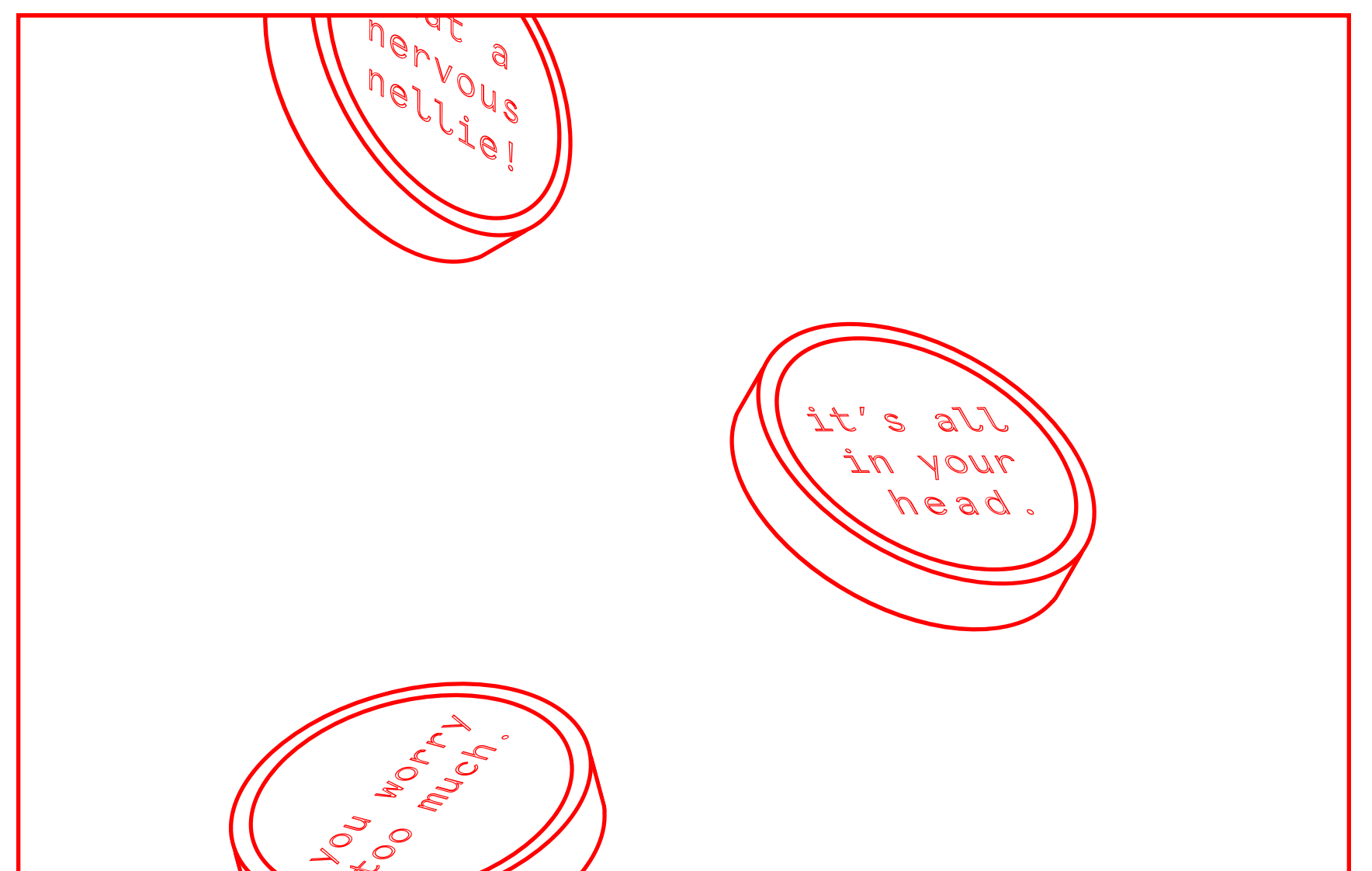

enjoy your personalized engraving on the deposited pill.

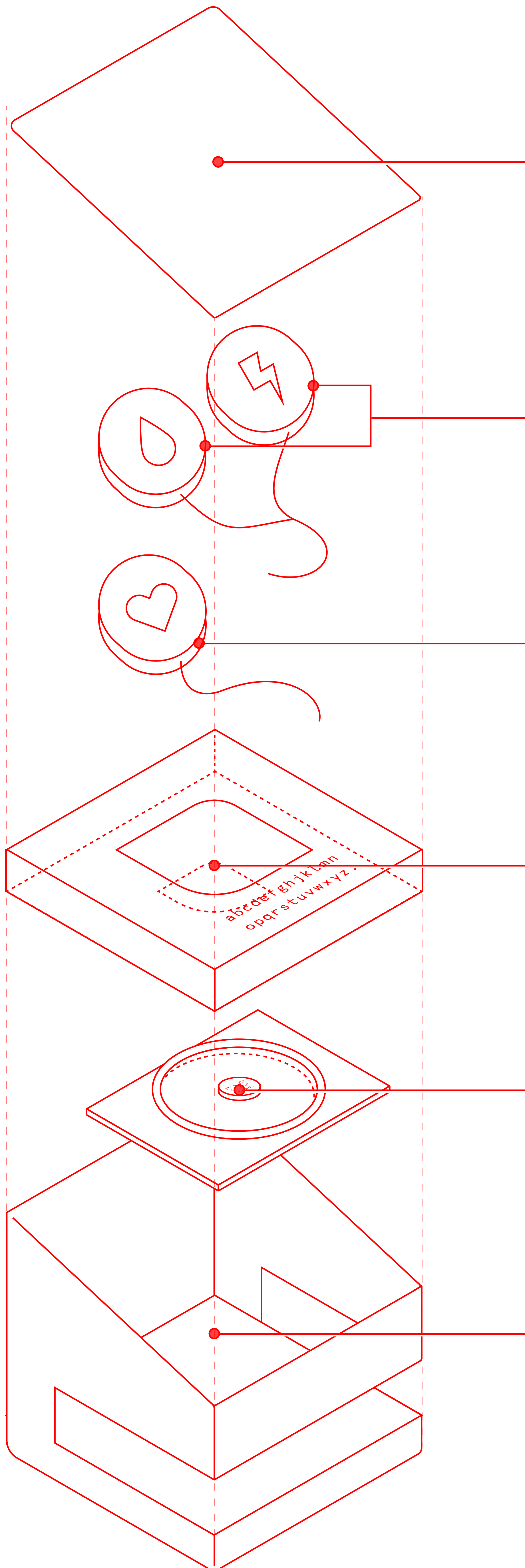

top surface
encapsulates sensors.
i just keep things pretty.

galvanic skin response sensor
your skin conducts electricity.
i can see you're nervous. don't sweat!

pulse sensor
ba-dump, ba-dump...
i can feel your heartbeat.

pill container & engraver
i'll store your pills
and personalize them, too!

pill dish
i'll deposit your medication here.

base container
hiding place for all the stuff above.

automated.





